

	KSF250-A1 Kawasaki CLUTCH COVER	MC 88-05 May 20, 1988
---	---	-------------------------------------

© 1988, Kawasaki Motors Corp., U.S.A.

Page 1 of 1

SERVICE INFORMATION

Subject

On some early production 1987 KSF250-A1 All Terrain Vehicles, extremely high oil pressure that builds up during cold weather starts may result in damage to the oil filter cover.

Parts Information

A new clutch cover that incorporates a threaded hole to allow for installation of an oil pressure relief valve is now available.

Description	Old Part No.	New Part No.
Clutch Cover	14032-1222	14032-1251
Relief Valve	N/A	18130-1001
Clutch Cover Gasket	11009-1589	→

CLUTCH COVER
(P/N 14032-1251)

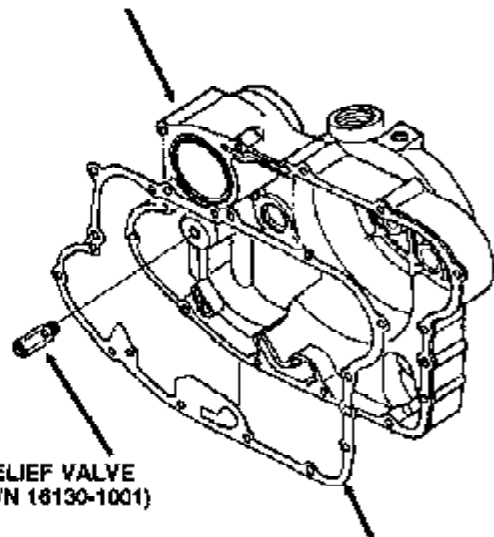

RELIEF VALVE
(P/N 18130-1001)

CLUTCH COVER
GASKET
(P/N 11009-1589)

NOTE:

- o The relief valve is not supplied with the new clutch cover and must be ordered separately. Install the relief valve inside the clutch cover as shown.
- o The new clutch cover uses the same gasket as the old one.
- o See Service Manual (P/N 99924-1067-01) for cover removal and installation.
- o Torque for the relief valve is 1.5 kg-m (11 ft-lbs, 14.7 N-m). Install the relief valve with a permanent locking agent.

CAUTION

- o Failure to install relief valve will cause severe engine damage due to lack of oil pressure.

Warranty Information

This bulletin is service information only, not warranty authorization.